



StarFive
赛昉科技

VisionFive 2 Datasheet

Version: 1.53

Date: 2023/04/28

Doc ID: VisionFive2-DSEN-001

Legal Statements

Important legal notice before reading this documentation.

PROPRIETARY NOTICE

Copyright © Shanghai StarFive Technology Co., Ltd., 2023. All rights reserved.

Information in this document is provided "as is," with all faults. Contents may be periodically updated or revised due to product development. Shanghai StarFive Technology Co., Ltd. (hereinafter "StarFive") reserves the right to make changes without further notice to any products herein.

StarFive expressly disclaims all warranties, representations, and conditions of any kind, whether express or implied, including, but not limited to, the implied warranties or conditions of merchantability, fitness for a particular purpose, and non-infringement.

StarFive does not assume any liability arising out of the application or use of any product or circuit, and specifically disclaims any and all liability, including without limitation indirect, incidental, special, exemplary, or consequential damages.

All material appearing in this document is protected by copyright and is the property of StarFive. You may not reproduce the information contained herein, in whole or in part, without the written permission of StarFive.

Contact Us

Address: Room 502, Building 2, No. 61 Shengxia Rd., China (Shanghai) Pilot Free Trade Zone, Shanghai, 201203, China

Website: <http://www.starfivetech.com>

Email:

- Sales: sales@starfivetech.com
- Support: support@starfivetech.com



Contents

List of Tables.....	4
List of Figures.....	5
Legal Statements.....	ii
Preface.....	vi
1. Overview.....	8
1.1. Block Diagram.....	8
2. Features.....	11
2.1. Hardware.....	11
2.2. Interfaces.....	11
2.3. Software.....	12
3. Mechanical Specification.....	13
4. Electrical Specification.....	15
4.1. Power Requirements.....	15
4.2. GPIO Voltage.....	15
5. Peripherals.....	16
5.1. GPIO Interface.....	16
5.1.1. GPIO Pin Assignments.....	16
5.1.2. GPIO Alternative Functions.....	17
5.2. eMMC Socket.....	17
5.3. Camera and Display Interfaces.....	17
5.3.1. 2-Lane MIPI DSI Pin Definition.....	18
5.3.2. 4-Lane MIPI DSI Pin Definition.....	19
5.4. USB Host.....	21
5.5. USB Device Port.....	21
5.6. HDMI.....	21
5.7. Audio Jack.....	21
5.8. M.2 Connector.....	21
5.9. Gigabit Ethernet Port.....	21
5.10. Boot Mode Pins.....	21
5.11. 4-Pin PoE Header.....	22
5.12. Fan Header.....	22
5.13. Button.....	22
5.14. Temperature Range and Thermals.....	22
6. Support.....	23

List of Tables

Table 0-1 Revision History.....	vi
Table 5-1 GPIO Pin Assignments.....	16
Table 5-2 2-Lane MIPI DSI Pin Definition.....	18
Table 5-3 4-Lane MIPI DSI Pin Definition.....	20



List of Figures

Figure 1-1 VisionFive 2 Block Diagram - Top View.....	9
Figure 1-2 VisionFive 2 Block Diagram - Bottom View.....	10
Figure 3-1 VisionFive 2 Mechanical Drawing (Top View).....	13
Figure 3-2 VisionFive 2 Mechanical Drawing (Bottom View).....	13
Figure 3-3 NPTHs on VisionFive 2.....	14
Figure 3-4 Single Head Hexagonal Copper Columns.....	14
Figure 3-5 Double Way Hexagon Copper Studs.....	14
Figure 5-1 2-Lane MIPI DSI Pin Definition.....	18
Figure 5-2 4-Lane MIPI DSI Pin Definition.....	19



StarFive
星昉科技

Preface

About this guide and technical support information.

About this document

This document mainly provides the users with the features and technical specifications for StarFive next generation single board computer - VisionFive 2.

Revision History

Table 0-1 Revision History





Version	Released	Revision
1.53	2023/4/28	Updated the note type as warning in Mechanical Specification (on page 13) .
1.52	2023/3/18	Added the note that the USB Type C port is used for power supply only.
1.51	2023/2/22	Revised the pin definition for MIP DSI.
1.5	2023/2/17	Added new sections: <ul style="list-style-type: none">• 2-Lane MIPI DSI Pin Definition (on page 18)• 4-Lane MIPI DSI Pin Definition (on page 19)
1.41	2023/2/2	Removed the power consumption specification. The data only applied to limited conditions and might be modified after internal ATE test.
1.4	2023/1/16	Added power consumption specification.
1.3	2022/12/8	Added a note about using spacers in Mechanical Specification (on page 13) . Updated the dimensions.
1.2	2022/10/20	<ul style="list-style-type: none">• Revised the display of MIPI CSI.• Updated the support information.• Updated the USB-C description.• Updated the GPU description.• Updated the Reset button description.• Updated USB Host (on page 21).• Added USB Device Port (on page 21).• Updated the pin assignments in GPIO Pin Assignments (on page 16).• Updated the block diagram.• Updated the description in Audio Jack (on page 21).
1.1	2022/09/08	<ul style="list-style-type: none">• Updated the mechanical drawings and the block diagram (bottom view).• Updated the description about Reset button.

Table 0-1 Revision History (continued)

Version	Released	Revision
1.0	2022/09/05	The first release.

Notes and notices

The following notes and notices might appear in this guide:

-  **Tip:**
Suggests how to apply the information in a topic or step.
-  **Note:**
Explains a special case or expands on an important point.
-  **Important:**
Points out critical information concerning a topic or step.
-  **CAUTION:**
Indicates that an action or step can cause loss of data, security problems, or performance issues.
-  **Warning:**
Indicates that an action or step can result in physical harm or cause damage to hardware.

1. Overview

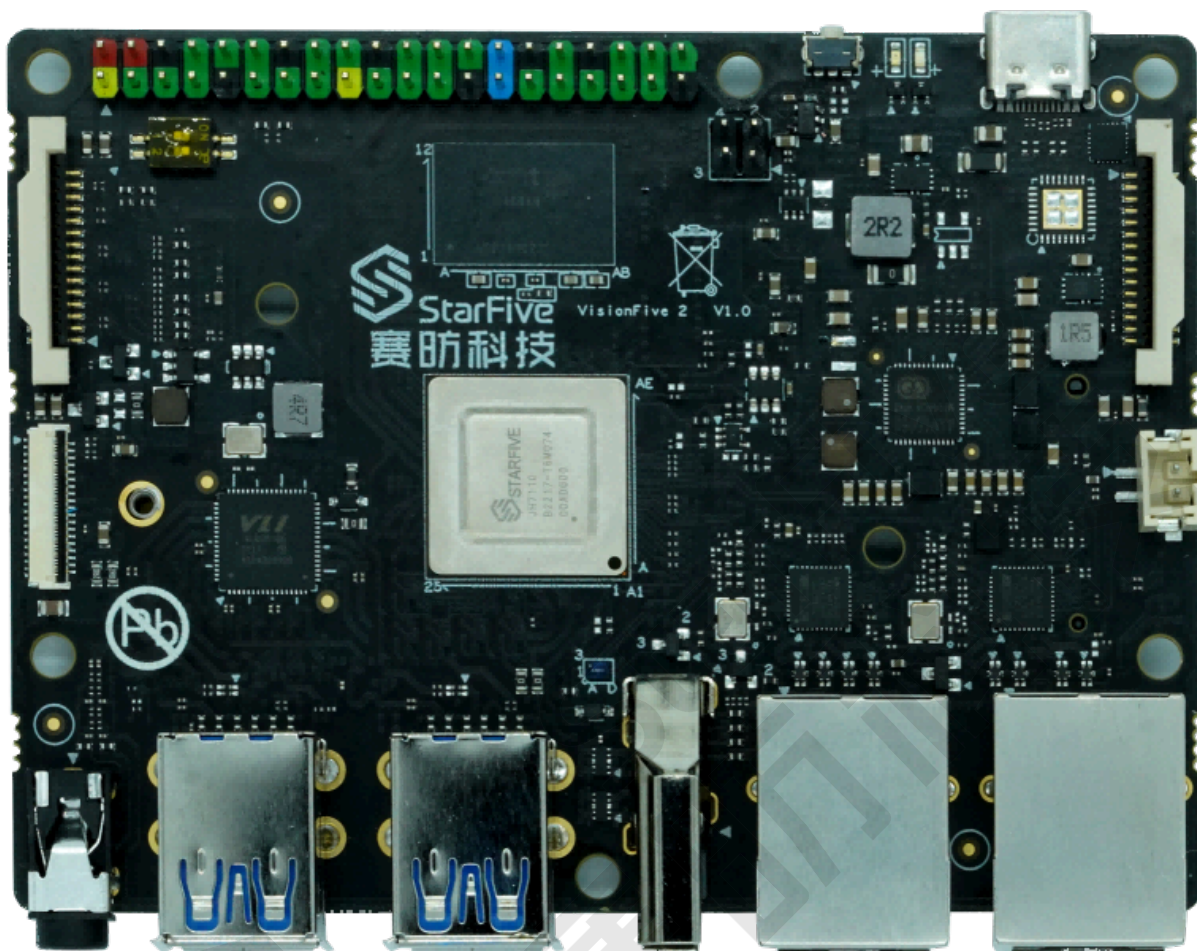

VisionFive 2 is the world's first high-performance RISC-V single board computer (SBC) with an integrated GPU. Compared with its last generation, VisionFive 2 has been fully upgraded with significant improvements in the processor work frequency, multimedia processing capabilities, scalability, etc. Its superior performance and reasonable price make VisionFive 2 the best affordable RISC-V development board ever.

VisionFive 2 boasts a quad-core 64-bit SoC with RV64GC ISA, running up to 1.5 GHz, and integrated with IMG BXE-4-32 MC1, supporting OpenCL 3.0, OpenGL ES 3.2, and Vulkan 1.2. Available with 2/4/8 GB LPDDR4 RAM options, VisionFive 2 provides rich I/O peripherals such as M.2 connector, eMMC socket, USB 3.0 ports, a 40-pin GPIO header, Gigabit Ethernet ports, a TF card slot, and many more. It has onboard audio and video processing capabilities and has MIPI-CSI and MIPI-DSI connectors as multimedia peripherals. The open source SBC also provides wide software compatibility including support for Debian.

1.1. Block Diagram

The following figure displays the block diagrams of VisionFive 2.

Figure 1-1 VisionFive 2 Block Diagram - Top View

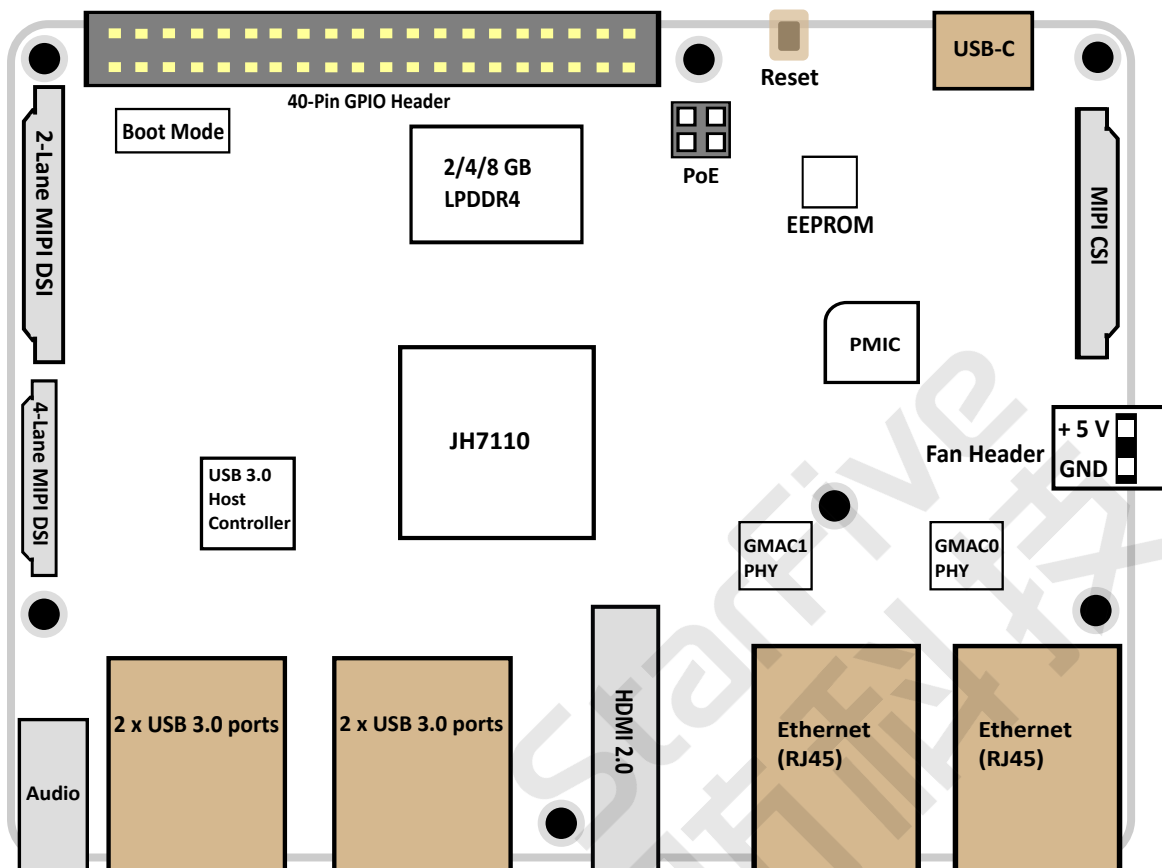
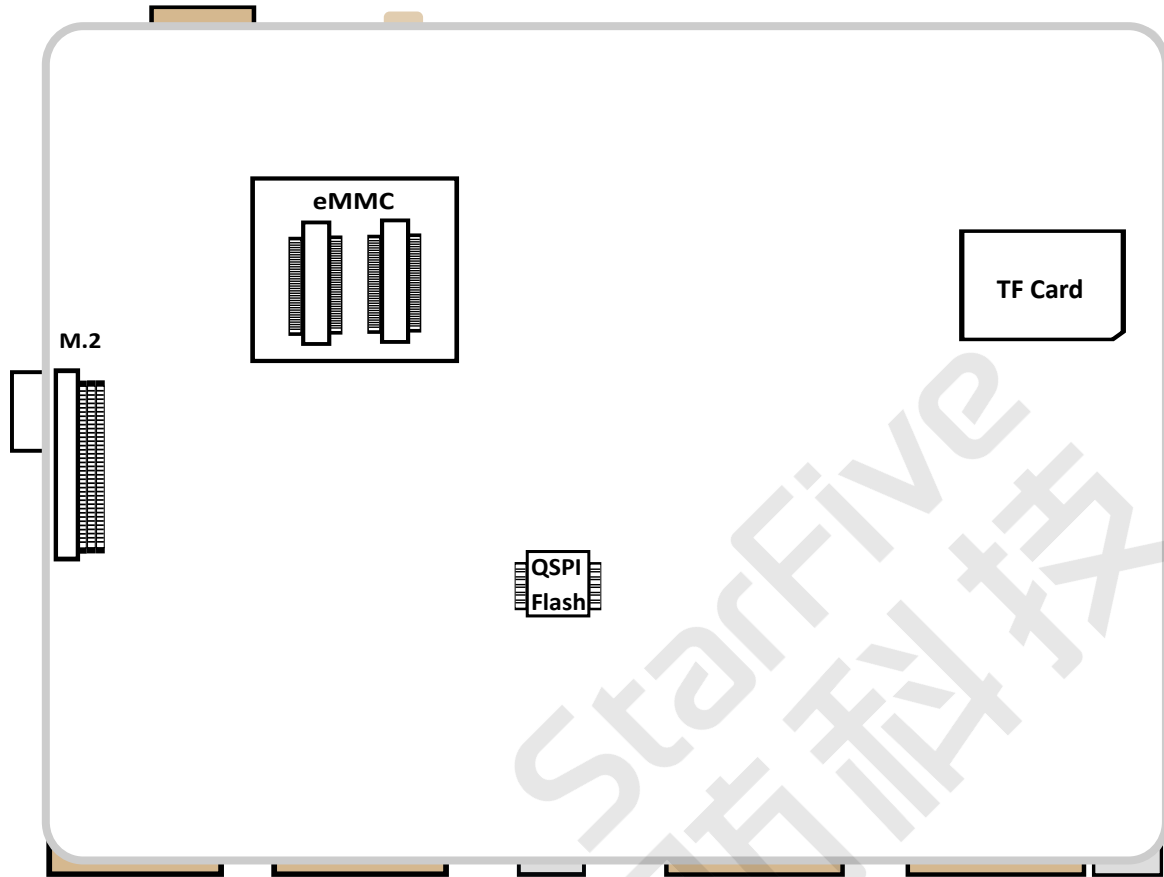

Figure 1-2 VisionFive 2 Block Diagram - Bottom View



2. Features

VisionFive 2 provides the following features.

- [Hardware \(on page 11\)](#)
- [Interfaces \(on page 11\)](#)
- [Software \(on page 12\)](#)

2.1. Hardware

This section describes the following VisionFive 2 hardware functions.

- [Processor \(on page 11\)](#)
- [Memory \(on page 11\)](#)
- [Video Processing \(on page 11\)](#)

Processor

- StarFive JH7110 with RISC-V quad-core CPU with 2 MB L2 cache and a monitor core, supporting RV64GC ISA, working up to 1.5 GHz
- IMG BXE-4-32 MC1 with work frequency up to 600 MHz

Memory

VisionFive 2 provides the system memory of 2 GB, 4 GB, or 8 GB LPDDR4 SDRAM up to 2,800 Mbps.

Storage

- Onboard TF card slot: The VisionFive 2 can boot from the TF card.
- Flash: The firmware to store U-Boot and bootloader.

Video Processing

The video processing of VisionFive 2 has the following features.

- Video decoder support up to 4K@60fps and multi-stream for H264/H265
- Video encoder support up to 1080p@30fps and multi-stream for H265
- JPEG encoder/decoder

2.2. Interfaces

- 1 × 2-lane MIPI DSI
- 1 × 4-lane MIPI DSI
- 1 × 2-lane MIPI CSI
- 1 × 3.5 mm Audio Jack
- 1 × USB-C port for charging
- 1 × USB device port (by reusing the USB-C port)
- 4 × USB 3.0 ports (multiplexed with a PCIe 2.0 1x lane)
- 1 × HDMI 2.0

- 2 × RJ45 Ethernet ports
- 1 × 4-pin PoE header
- 1 × 2-pin fan header
- 1 × Reset button
- 1 × 40-pin GPIO header, supporting various interface options:
 - 3.3 V (on 2 pins)
 - 5 V (on 2 pins)
 - Ground (on 8 pins)
 - GPIO
 - CAN bus
 - DMIC
 - I2C
 - I2S
 - PWM
 - SPI
 - UART
 - and so on

2.3. Software

Operating System

VisionFive 2 supports Debian operating system.

For more software resources, please follow the [StarFive GitHub repository](#).

3. Mechanical Specification

The mechanical drawing of VisionFive 2 is as the following:

Figure 3-1 VisionFive 2 Mechanical Drawing (Top View)

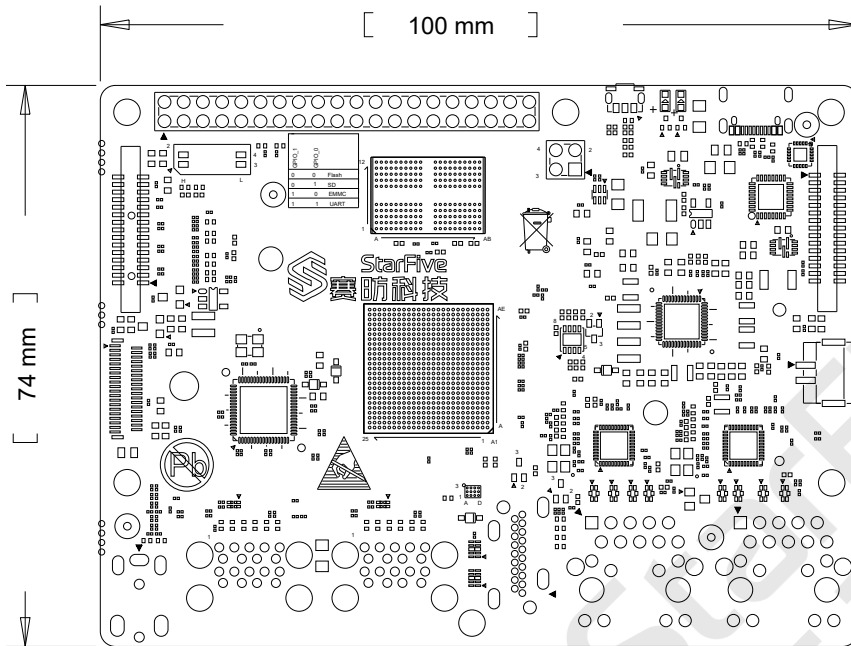
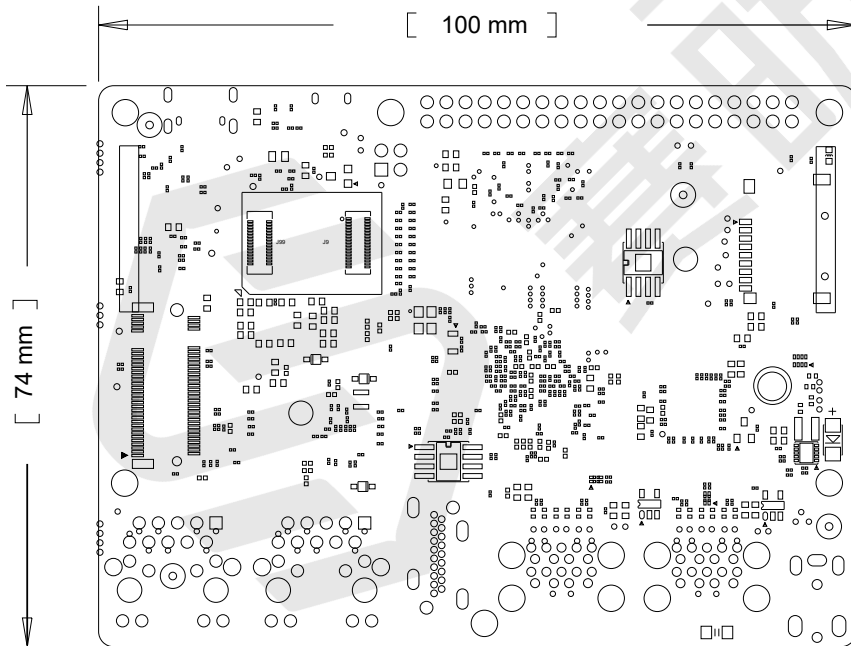

Figure 3-2 VisionFive 2 Mechanical Drawing (Bottom View)



Dimensions

VisionFive 2 has the following dimensions.

- Length: 100 mm
- Width: 74 mm

Warning:

During the use of VisionFive 2, avoid contact with hard objects that may cause damage. Thus, StarFive recommends that you use spacers for the following NPTHs (Non Plating Through Hole):

Figure 3-3 NPTHs on VisionFive 2

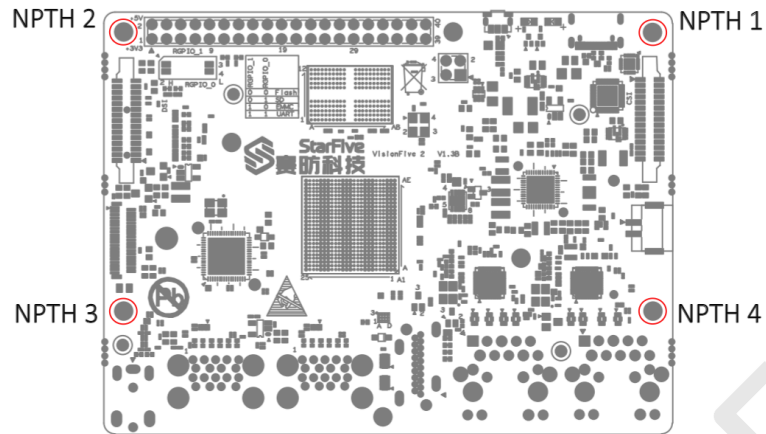

For spacers, StarFive strongly recommends that you use the copper columns or studs with the following specifications:

- Single head hexagonal copper columns (Size: M2.5*10+6mm)

Figure 3-4 Single Head Hexagonal Copper Columns

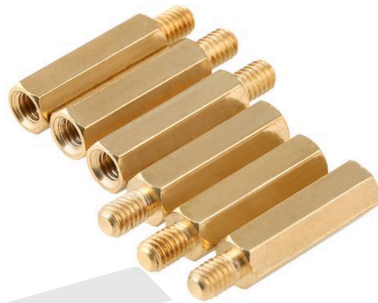

- Double way hexagon copper studs (Size: M2.5*4)

Figure 3-5 Double Way Hexagon Copper Studs



4. Electrical Specification

This chapter describes the VisionFive 2 electrical specification.

- [Power Requirements \(on page 15\)](#)
- [GPIO Voltage \(on page 15\)](#)

4.1. Power Requirements

Input Power

VisionFive 2 supports various ways of powering, smart power adapter as well as fixed voltage:

- USB PD 2.0
- Support USB Type C PD 2.0, 9 V/2 A, 12 V/2 A, 15 V/2 A, 20 V/2 A
- Qualcomm® Quick Charge™ 2.0
- Support QC3.0/2.0 adapter, 9 V/2 A, 12 V/1.5 A
- Power adapter with fixed voltage from 5 V to 20 V on the USB C power port
- 5 V Power from the GPIO Pin 2 and 4



Note:

The USB Type C port on VisionFive 2 is used for power supply only. To avoid power surge, which may trigger power-surge protection and deteriorate the board performance, make sure the board is fed by one power source at a time. Use USB port for data transmission, DO NOT reuse this port for both power supply and data transmission.

4.2. GPIO Voltage

The required voltage level for all GPIO pins is 3.3 V.

5. Peripherals

VisionFive 2 has the following peripherals.

- [GPIO Interface \(on page 16\)](#)
- [eMMC Socket \(on page 17\)](#)
- [Camera and Display Interfaces \(on page 17\)](#)
- [USB Host \(on page 21\)](#)
- [HDMI \(on page 21\)](#)
- [Audio Jack \(on page 21\)](#)
- [M.2 Connector \(on page 21\)](#)
- [Gigabit Ethernet Port \(on page 21\)](#)
- [Button \(on page 22\)](#)
- [Temperature Range and Thermals \(on page 22\)](#)

5.1. GPIO Interface

VisionFive 2 offers 40-Pin GPIO expansion which is compatible with most accessories on the market, supporting various interface options:

- 3.3 V (on 2 pins)
- 5 V (on 2 pins)
- Ground (on 8 pins)
- GPIO
- CAN bus
- DMIC
- I2C
- I2S
- PWM
- SPI
- UART
- and so on

5.1.1. GPIO Pin Assignments

The following table describes the GPIO pin assignments.

Table 5-1 GPIO Pin Assignments

Pin Name	Pin Num	Pin Num	Pin Name
+3.3V	1	2	+5V
GPIO58 (I2C SDA)	3	4	+5V
GPIO57 (I2C SCL)	5	6	GND
GPIO55	7	8	GPIO5 (UART TX)

Table 5-1 GPIO Pin Assignments (continued)

Pin Name	Pin Num	Pin Num	Pin Name
GND	9	10	GPIO6 (UART RX)
GPIO42	11	12	GPIO38
GPIO43	13	14	GND
GPIO47	15	16	GPIO54
+3.3V	17	18	GPIO51
GPIO52 (SPI MOSI)	19	20	GND
GPIO53 (SPI MISO)	21	22	GPIO50
GPIO48 (SPI SCLK)	23	24	GPIO49 (SPI CE0)
GND	25	26	GPIO56
GPIO45	27	28	GPIO40
GPIO37	29	30	GND
GPIO39	31	32	GPIO46 (PWM0)
GPIO59 (PWM1)	33	34	GND
GPIO63	35	36	GPIO36
GPIO60	37	38	GPIO61
GND	39	40	GPIO44

5.1.2. GPIO Alternative Functions

All GPIOs can be switched (multiplexed) to support different functions including but not limited to SDIO, Audio, DMIC, SPI, I2C, UART, PWM, and CAN bus. For detailed instructions, refer to the *VisionFive 2 40-Pin GPIO Header User Guide* (coming soon). The alternate peripheral functions are described in detail in the [JH7110 Datasheet](#).

5.2. eMMC Socket

VisionFive 2 offers a high speed eMMC socket for eMMC modules as OS and data storage. The eMMC socket is compatible with industrial commonly used pinout and form factor.

5.3. Camera and Display Interfaces

The following connectors are backward compatible with other industrial commonly used camera and display peripherals.

Camera

VisionFive 2 has 1 × 2-lane MIPI CSI camera port, supporting up to 1080p@30fps

Display

VisionFive 2 has the following interfaces for camera and display.

- 1 × 2-lane MIPI DSI display port, supporting up to 1080p@30fps

For the pin definition, see [2-Lane MIPI DSI Pin Definition \(on page 18\)](#)

- 1 × 4-lane MIPI DSI display port, supporting up to 2K@30fps in both single display and dual display modes.

For the pin definition, see [4-Lane MIPI DSI Pin Definition \(on page 19\)](#).

- 1 × HDMI 2.0, supporting up to 4K@30fps or 2K@60fps



Note:

Only one MIPI DSI port can be used for display at a time.

5.3.1. 2-Lane MIPI DSI Pin Definition

The following figure and table describe the 2-lane MIPI DSI definition:

Figure 5-1 2-Lane MIPI DSI Pin Definition

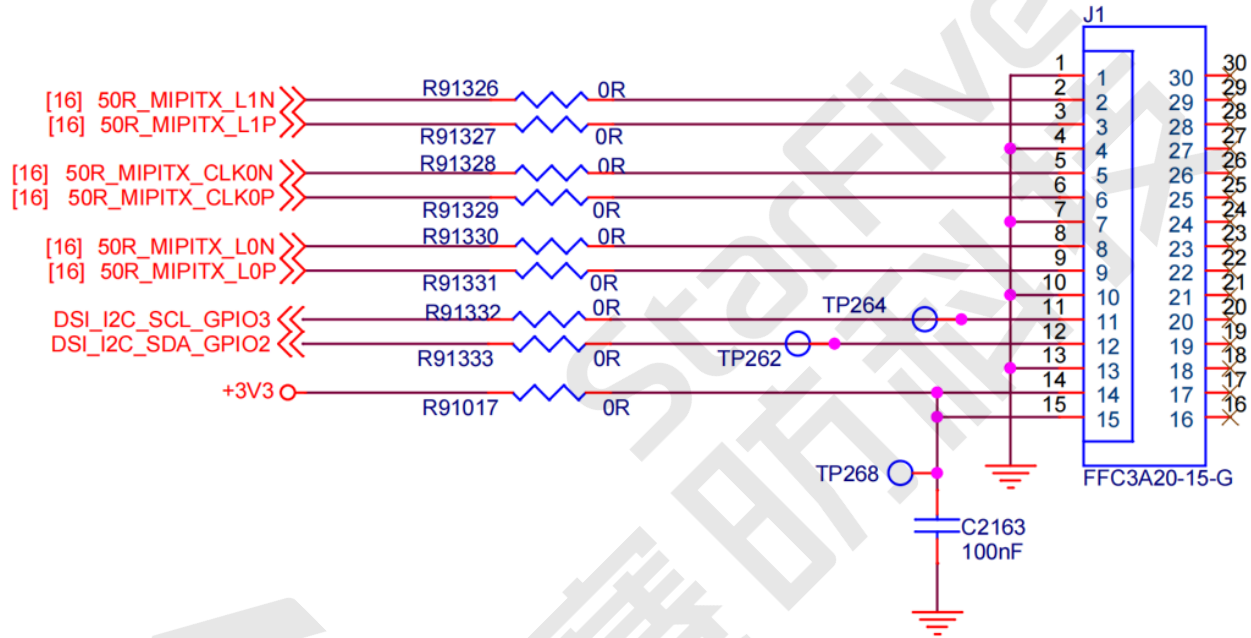

Table 5-2 2-Lane MIPI DSI Pin Definition

No.	Definition	Description	Voltage
1	GND	Ground	-
2	50R_MIPITX_L1N	MIPI Output Lane 1 Negative	1.8 V
3	50R_MIPITX_L1P	MIPI Output Lane 1 Positive	1.8 V
4	GND	Ground	-
5	50R_MIPITX_CLK0N	MIPI Output Clock 0 Negative	1.8 V
6	50R_MIPITX_CLK0P	MIPI Output Clock 0 Positive	1.8 V
7	GND	Ground	-
8	50R_MIPITX_L0N	MIPI Output Lane 0 Negative	1.8 V
9	50R_MIPITX_L0P	MIPI Output Lane 0 Positive	1.8 V
10	GND	Ground	-
11	DSI_I2C_SCL_GPIO3	DSI I2C SCL	3.3 V
12	DSI_I2C_SDA_GPIO2	DSI I2C SDA	3.3 V

Table 5-2 2-Lane MIPI DSI Pin Definition (continued)

No.	Definition	Description	Voltage
13	GND	Ground	-
14	+3.3 V	Power Voltage for digital circuit 3.3 V	3.3 V
15	GND	GND	1.8 V

5.3.2. 4-Lane MIPI DSI Pin Definition

The following figure and table describe the 4-lane MIPI DSI definition:



Note:

The compatible model is CZ101B4001.

Figure 5-2 4-Lane MIPI DSI Pin Definition

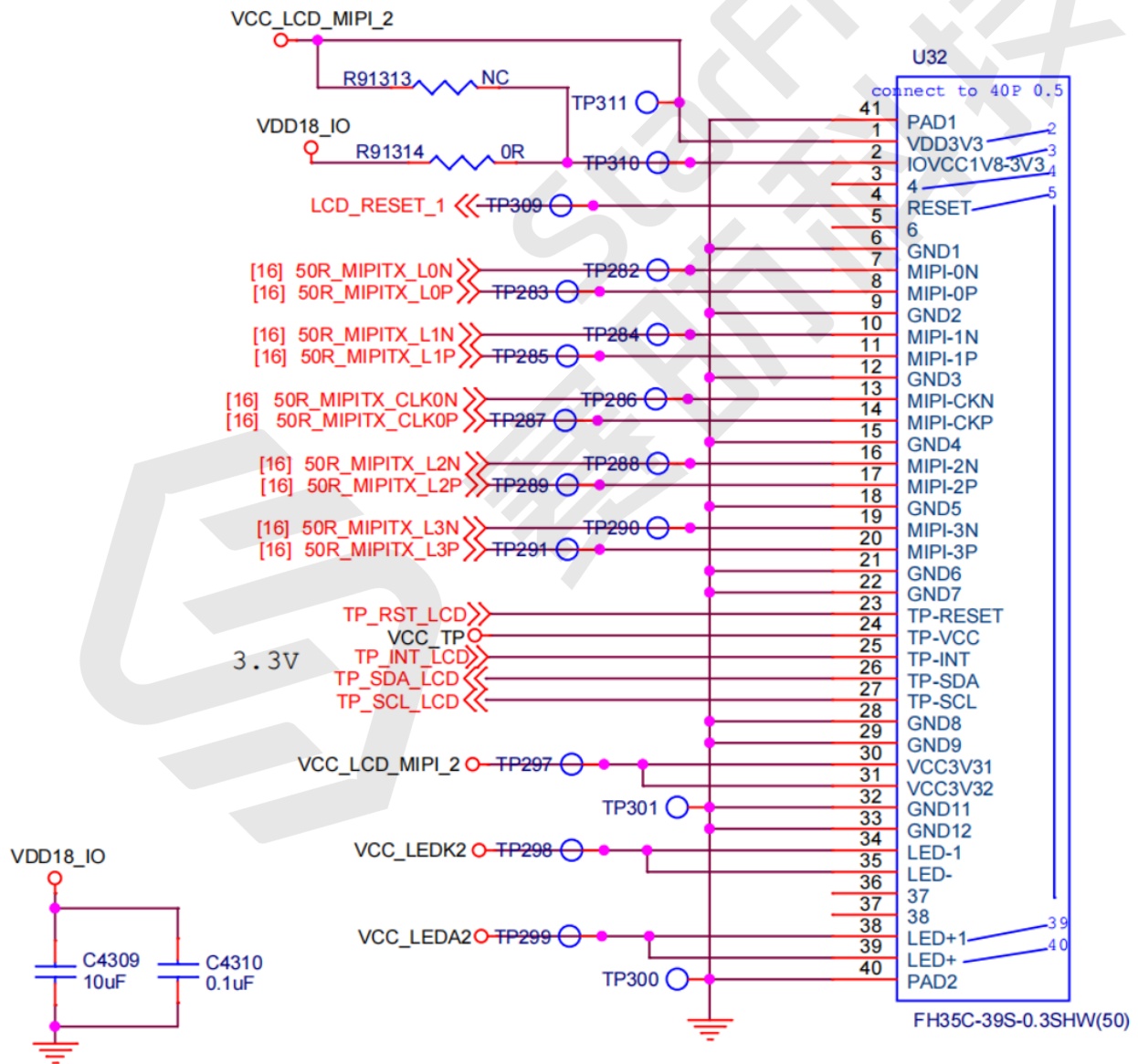

Table 5-3 4-Lane MIPI DSI Pin Definition

PIN NO.	Pin Definition	Description	Voltage
1	VCC_LCD_MIPI_2	Power Voltage for digital circuit 3.3 V	3.3 V
2	VDD18_IO	Power Voltage for digital circuit 1.8 V Note 1	1.8 V
3	NC	No connection	-
4	LCD_RESET_1	Global reset pin 1.8V Note 1	1.8 V
5	NC	No connection	-
6	GND	Ground	-
7	50R_MIPITX_L0N	MIPI Output Lane 0 Negative	1.8 V
8	50R_MIPITX_L0P	MIPI Output Lane 0 Positive	1.8 V
9	GND	Ground	-
10	50R_MIPITX_L1N	MIPI Output Lane 1 Negative	1.8 V
11	50R_MIPITX_L1P	MIPI Output Lane 1 Positive	1.8 V
12	GND	Ground	-
13	50R_MIPITX_CLK0N	MIPI Output Clock 0 Negative	1.8 V
14	50R_MIPITX_CLK0P	MIPI Output Clock 0 Positive	1.8 V
15	GND	Ground	-
16	50R_MIPITX_L2N	MIPI Output Lane 2 Negative	1.8 V
17	50R_MIPITX_L2P	MIPI Output Lane 2 Positive	1.8 V
18	GND	Ground	-
19	50R_MIPITX_L3N	MIPI Output Lane 3 Negative	1.8 V
20	50R_MIPITX_L3P	MIPI Output Lane 3 Positive	1.8 V
21	GND	Ground	-
22	GND	Ground	-
23	TP_RST_LCD	TP_RESET	3.3 V
24	VCC_TP	TP_VCC	3.3 V
25	TP_INT_LCD	TP_INT	3.3 V
26	TP_SDA_LCD	TP_SDA	3.3 V
27	TP_SCL_LCD	TP_SCL	3.3 V
28	GND	Ground	-
29	GND	Ground	-
30	VCC_LCD_MIPI_2	Power Voltage for digital circuit 3.3 V	3.3 V
31	VCC_LCD_MIPI_2	Power Voltage for digital circuit 3.3 V	3.3 V
32	GND	Ground	-
33	GND	Ground	-

Table 5-3 4-Lane MIPI DSI Pin Definition (continued)

PIN NO.	Pin Definition	Description	Voltage
34	VCC_LEDK2	LED Cathode	Up to 30 V. The adjustable output voltage can be controlled by MIPI_PWR_EN . The voltage is adjustable and the value depends on the back-light requirement. The voltage level of the 4-lane MIPI screen, which has been tuned by StarFive, VCC_LEDK2 ranges from 9 V to 10.5 V.
35	VCC_LEDK2	LED Cathode	
36	NC	No connection	-
37	NC	No connection	-
38	VCC_LED A2	LED Anode	0 V
39	VCC_LED A2	LED Anode	0 V
40	PAD1	The fixed pin to be connected to GND.	-
41	PAD2	The fixed pin to be connected to GND.	-

5.4. USB Host

VisionFive 2 has 4 × USB 3.0 ports (multiplexed with a PCIe 2.0 1x lane).

5.5. USB Device Port

VisionFive 2 has 1 × USB device port by reusing the USB-C port.

5.6. HDMI

VisionFive 2 has 1 × HDMI port, supporting HDMI 2.0 with resolutions up to 4K@30fps or 2K@60fps.

5.7. Audio Jack

VisionFive 2 supports analog audio output via a 4-ring 3.5 mm headphone jack.

5.8. M.2 Connector

VisionFive 2 offers an M.2 M-Key SSD socket with 1 × PCIe 2.0 interfaces, providing high speed storage access.

5.9. Gigabit Ethernet Port

VisionFive 2 has 2 × RJ45 Gigabit Ethernet ports.

5.10. Boot Mode Pins

VisionFive 2 provides pins to determine the boot mode before it is powered up. The following are the available boot modes:

- 1-bit QSPI Nor Flash
- SDIO3.0
- eMMC
- UART

5.11. 4-Pin PoE Header

VisionFive 2 provides Power over Ethernet (PoE) function. PoE carries electrical power through data cables, and reduces the cabling requirements for network devices. You can use this function by adding a separate PoE HAT out of our product package.

5.12. Fan Header

VisionFive 2 has a 2-pin fan header. You can connect a 2-pin 5 V fan to the board if needed.

5.13. Button

VisionFive 2 provides 1 × Reset button.



Note:

To reset VisionFive 2, press and hold the Reset button for more than 3 seconds to ensure the reset is successful.

5.14. Temperature Range and Thermals

The recommended ambient operating temperature range is 0 to 50 degrees Celcius.

To reduce thermal output when idling or under light load, VisionFive 2 reduces the CPU clock speed and voltage. During heavier load, the speed and voltage (and hence thermal output) are increased. The internal governor will throttle back both the CPU speed and voltage to make sure the CPU temperature never exceeds 85 degrees C.

VisionFive 2 will operate perfectly well without any extra cooling and is designed for sprint performance - expecting a light use case on average and ramping up the CPU speed when needed (for example, when loading a webpage). If a user wishes to load the system continually or operate it at a high temperature at full performance, further cooling may be needed.

6. Support

For support, post questions to the [RVspace](#) forum.

